



BRDR. CHRISTENSEN
CREATING QUALITY VALVES WORLDWIDE

brdrchristensens.com



Taper Twin Plug Valves

**Class 150-300-600-900-1500 and 2500
Pressure Balanced Design**



CHRISTENSEN
Cavity Relief System





Brdr. Christensen is a private owned company, which started the business adventure in 1942, and since 1958 the company has been manufacturer of quality plug valves worldwide. The company mission is by using employees with the very highest technical valve competences we will create the best dialog to succeed designing and manufacturing quality valves for the global oil and gas industry.



Foundry, pattern and Machine shop in Denmark



10.000 kg of metal being poured



16" class 600 twin plug pattern



The Christensen lubricated taper plug valves are ideal shut of valves for almost any medium, especially under the most severe operating conditions. The pressure balanced design means that the plug is provided with pressure balance holes, which ensure that the plug is always in axial balance and consequently prevents the plug from taper locking

The twin Plug Valves – Or Double Block and Bleed – were developed in 1993 as a result of several major oil companies expressing a increasing need for a verifiable double isolation plugvalve, fully complying with both ASME and API codes. The idea was to design a double plug in one body house, with the same face to face dimensions as the single valves have. The valves were to be used in high explosive area's where verifiable double isolation valves are required.

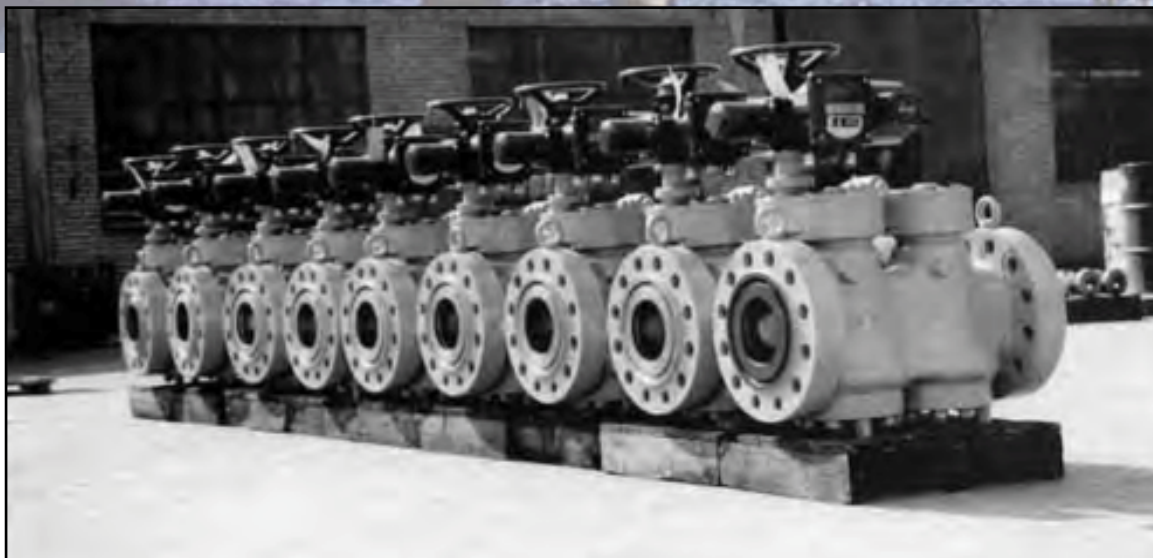

Today Christensen has supplied several thousand double block and bleed valves in sizes from 1" to 24" in the Classes 150 to 2500. The valves are working under extreme conditions from Alaska to the North Sea and from South America to the Middle East area.



When we designed the new twinplug we developed a new feature, which no other valves had –we call it the CCR System. The CCR System is patented and is a special designed bore, going from the body sealing surface against the diaphragm, to the post outside of each plug.

CHRISTENSEN

Cavity Relief System



The CCR System avoids overpressure in the cavity between the two plugs, if an emergency situation should occur – if the cavity pressure should increase – due to an explosion, fire ect. The Pressure against the bottom cover will cause the studs to stretch and then open up for relief back into the feed pipeline, and no dangerous gasses/mediums will escape out into the atmosphere. When the pressure falls again the studs retract the bottom cover back to normal position, which closes the bore.



Technical information – Section A

The Design of the Twin plug	A 6
Twin Plug Pattern	A 8
Christensen Code System	A 9
Christensen Code System	A 10
Materials of Construction	A 11
List of standards and colour code	A 12
Operation	A 13
Method of operation	A 14
Wrenches	A 15
Valve connections	A 16
BCH Standard valve data sheet	A 17

Threaded holes in main connection Flanges	A 18
---	------

Valve identification – Section B

Class 150, Operation by Wrench Actuator ISO top Flange or manuel gear box	B 19/20
--	---------

Class 300, Operation by Wrench Actuator ISO top Flange or manuel gear box	B 21/22
--	---------

Class 600, Operation by Wrench Actuator ISO top Flange or manuel gear box	B 23/24
--	---------

Class 900, Operation by Wrench Actuator ISO top Flange or manuel gear box	B 25/26
--	---------

Class 1500, Operation by Wrench Actuator ISO top Flange or manuel gear box	B 27/28
---	---------

Class 2500, Operation by Wrench Actuator ISO top Flange or manuel gear box	B 29/30
---	---------

Topwork Actuator Flange Acc. to ISO 5211	B 31/32
--	---------

Maintenance/Operation/Testing

Valve characteristic – Section C

Valve lubrication	C 33
Maintenance/Operations instructions	C 34
Maintenance/Operations instructions	C 35
Sealing compoud recommendation	C 36
Quality control	C 37
Pressure Test/Inspection	C 38
Weight, Torque and CV valves	C 39
Twin plug valve fact sheet	C 40

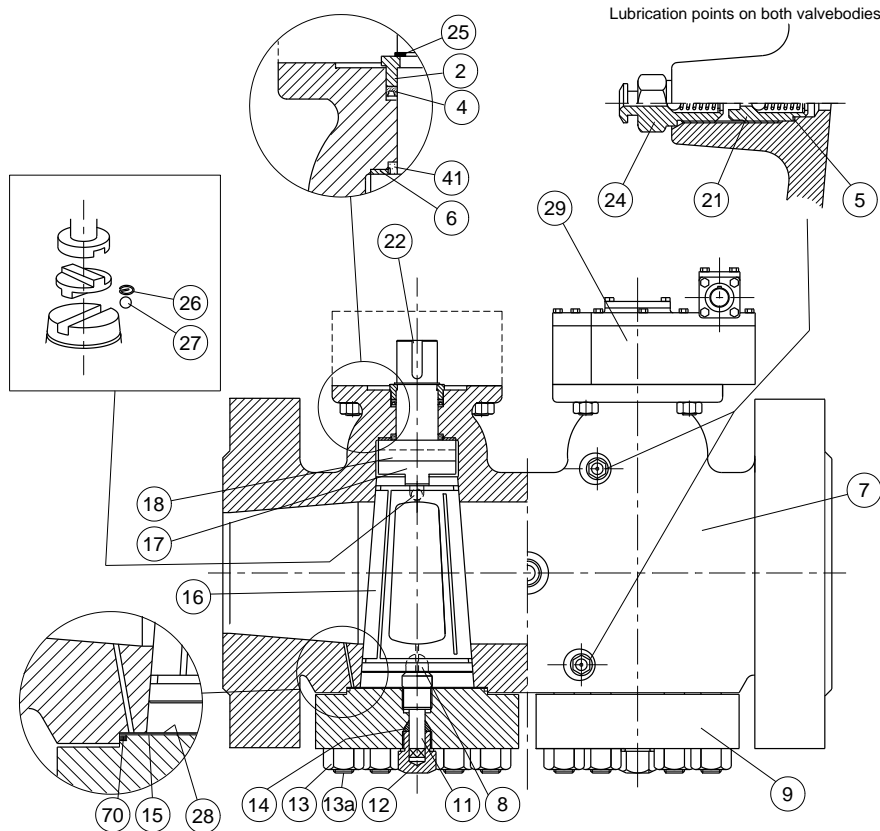

- Part No.:
2. Stembearing
 4. Sealing Ring
 5. Gasket
 6. Thrust Plate
 7. Body
 8. Distance Piece
 9. Bottom Cover
 11. Pressure Screw
 12. Bottom Screw
 13. Nut
 - 13a. Stud
 14. Retaining Ring
 15. Diaphragm
 16. Plug
 17. Equalizer Ring
 18. Operating Stem
 21. Check Valve
 22. Parallel Key
 24. Lubricant Screw
 25. Snap Ring
 26. Spring
 27. Ball
 28. Diaphragm
 29. Gearbox
 41. Fire Seal
 70. Sealing Ring

The Christensen lubricated twin plug valve is designed for use in critical applications where, verifiable tight shutoff is demanded. The design of the Twin Plug Valve is very compact, space and weight is minimized. Furthermore, the design has far less possible leak paths compared to the conventional Double Block & Bleed Valve assemblies. In most sizes and pressure classes, the face to face dimensions of this valve are the same as for a single plug valve or ball valve.

Since the only moving parts are the plug and the stem, the basic operation of the valve is very simple. When the plug is turned 90°, the valve moves from closed to open position – and vice versa.

The plug is tapered 1:6 and is individually fitted to the valve body with very close tolerances. It incorporates Metal to Metal sealing, which means that no soft seal will be damaged by the flowing medium.

As a secondary seal, the valve is provided with a lubrication system which allows feeding a special lubricant into the valve while the valve is in operation.

Besides, sealing, the purpose of the lubricant is to protect the internals of the valve against corrosion and wear as well as reducing the valve torque.

The valve is manufactured in a “Pressure Balanced Design”, this means that the plug is provided with pressure balance holes, which ensure that the plug is always in axial balance and consequently prevents the plug from taper locking. Furthermore, in order to reduce the valve torque, the surface of the plug is coated with P.T.F.E. Film.

The plug and the operating stem are two separate parts, which are connected by means of an equalizer ring acting as a universal joint. The stem is Blowout-proof. This means the only way to remove it is from the bottom after the valve is disassembled.



With three independent seals the stem sealing of the Christensen valve is unique. This is made up of a reinforced P.T.F.E. Thrust plate (6) followed by a 100% pure graphite seal with a stainless steel back.up ring (41). The graphite seal is very efficient at extremely high temperatures, and meets the most strict demands of several different standards relative to fire safe design. At the top of the stem, the primary seal (sealing ring) is placed (4). The sealing ring is P.T.F.E. (teflon) with a special alloy spring. The ring can be replaced from the outside. The sealing ring is kept in a place by the stem bearing (2) and the snap ring/locking ring (25)

In addition to the stem seals mentioned, the wrench operated valve has a weatherproof seal to prevent penetration of water and dirt into the stem.

The bottom cover (9) is bolted on the valve body, with the studs (13a) and the nuts (13). Two flexible plates of diaphragms (15) and (28) are placed in a recess between the valve body and the bottom cover. They operate as a metal seal between the valve body and the bottom cover in order to prevent the medium from leaking at the adjustment arrangement pressure screw (11), the retaining ring (14) and the bottom screw (12).

The CCR System (Christensen Cavity Relief System)

A new feature has been added to protect against possible overpressure in the inner cavities (between, in and below the two plugs), this feature is a patented pressure relief bore. This feature is a bore going from the body sealing surface against the diaphragm, to the port outside of each plug. While operating normally, the bore is kept closed by the pressure of the bottom cover, obtained by studs and nuts, against the diaphragms.

If an overpressure occurs, while both plugs are in the closed position, e.g. if the valve is exposed to thermal stress, the pressure against the bottom cover will cause the studs to stretch and then open the relief, so the pressure escapes into the pipeline, and not out in the atmosphere. As the pressure falls the studs retract the bottom cover back into place and close the bore.

Besides the metal to metal sealing between body and bottom cover a pure graphite sealing ring (70) is installed.

A bleed port is available in configuration as per customer preference. This port allows access to verify the sealing of the valve itself. Any leakage past the first plug would be detected via the bleed port.

The plug adjustment within the valve body means of a pressure screw (11) and is kept in place by the retaining ring (14) when the bottom screw (12) is tightened. All adjustments to the plug are accomplished by a "flexing" of the two diaphragms.

As mentioned, the valve is provided with a lubrication system which allows penetration of special lubricant into the valve through lubricant screws (24) and check valves (21). The lubricant is injected into a network of grooves by means of a special high pressure lubricant gun. This network system ensures that all seal faces are supplied with a thin coat of lubricant which acts as a secondary seal.

The valve can be supplied as wrench operated or gear operated. On the gear operated valve the gear can be rotated 180° if needed.

Moreover, the Twin Plug valve is designed with ISO top as standard, which allow mounting of any kind of actuator. The Christensen Twin Plug is fully bidirectional and can be mounted in any position including upside down. Locking devices, sequential locking devices etc. are all available upon request.



Twin Plug Pattern

All Christensen Twin Plug Valves are designed to keep flow transitions to a minimum. The in line design gives maximum port areas with minimal flow profile changes. This results in Cv rates among the highest in the industry.

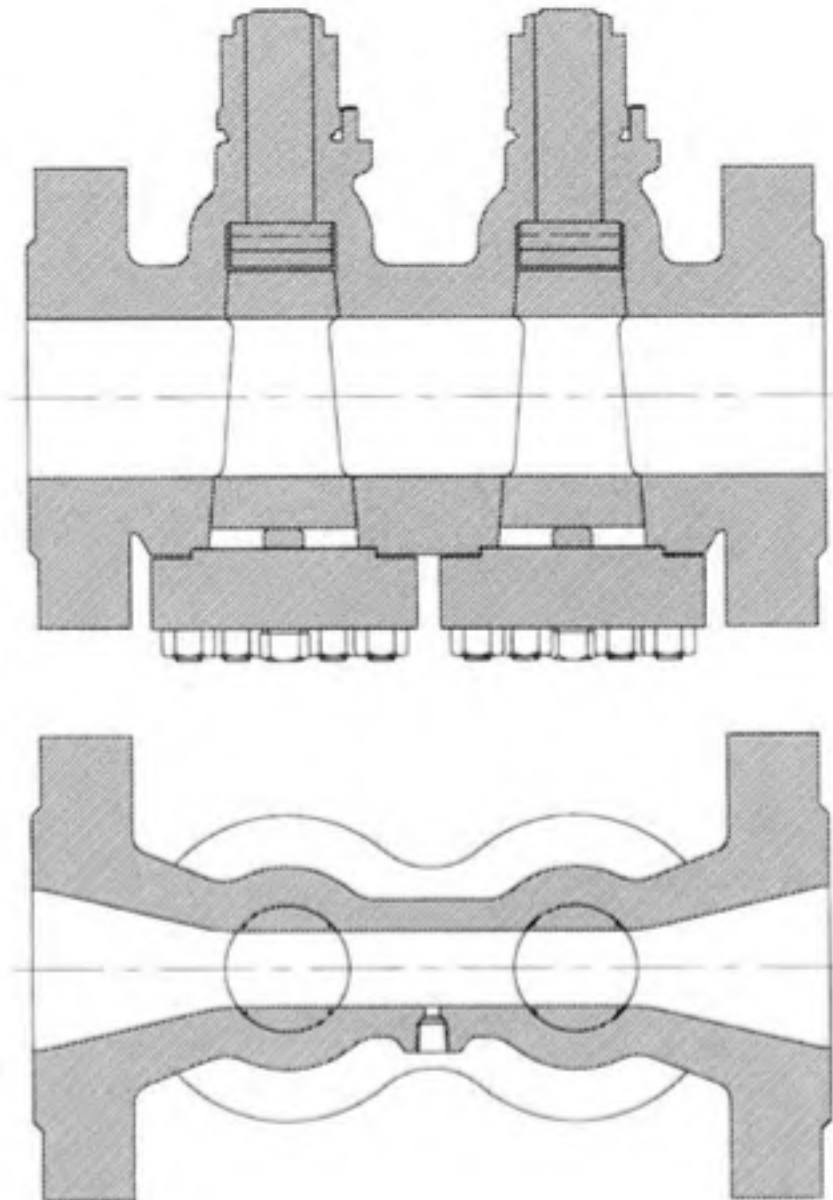

The design has only one recovery nozzle (outlet of 2nd plug). The flow rates of the Brdr. Christensen Twin Plug Valves are quite high and result in less pressure drop than witnessed with two separate single plug valves of equal size. The valve is bidirectional.



This catalogue covers Twin Plug Valves in the **taper plug design** to the ASME pressure class 150 – 300 – 600 – 900 – 1500 and 2500.

For information on valve types not covered by this catalogue, please contact our sole agent/representative in your country.

To identify the correct types of valve, please use the figure number key on the following page, by means of which the valve figure number is specified in the shape of letters and digits.

Additional to the figure number, quantify and size, please state the following information:

- Application
- Range of temperature
- Normal working pressure
- Type of flanges (raised face/ring joint or other)
- Dimension of pipe (only when valves have butt or socket welding ends)
- Accessories, if any

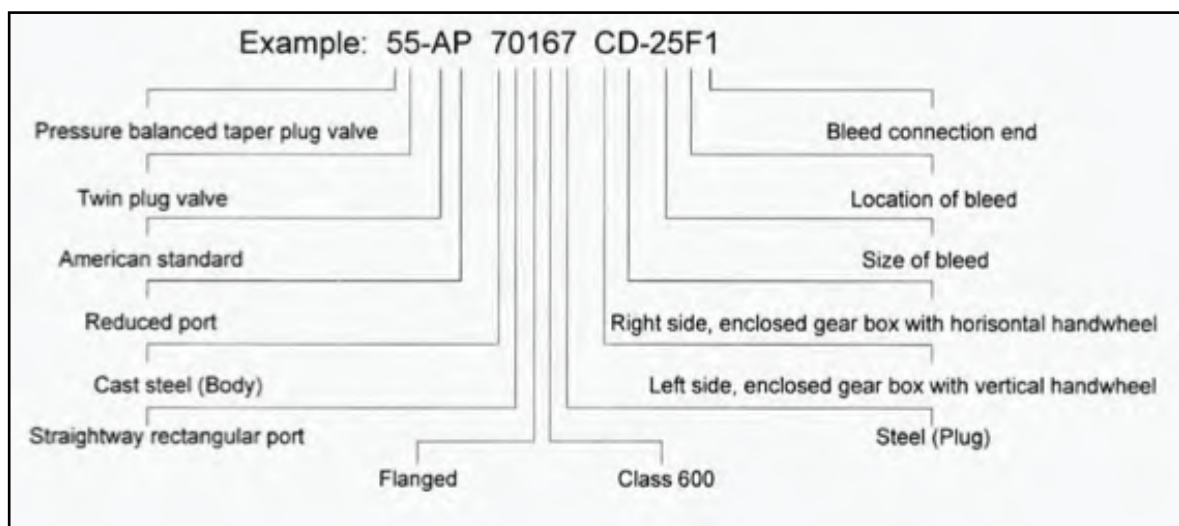



A telling code system
Create the number key for Twin Plug Valve

		1	2	3	4	5	6	7	8	9	10	11
Product group	TwinValve (tapered plug) "Pressure Balanced Design	55										
Standard	American API 6A American (API 6D, API 599, ect.)		- AE - AP									
Materials in body	Ductile Iron Cast Iron Cast Steel Stainless Steel Special Allow Steel (To order)			2 4 7 8 9								
Port	Straightway, rectangular Straightway, round				0 1							
Connection	Screwed Ends Flanged Ends Clamps Hubs Welding Ends Socket Welding Ends					0 1 4 5 6						
Pressure stage	Class 125 Class 150 (PN 20) Class 250 Class 300 (PN 50) Class 400 (PN 64) Class 600 (PN 100) Class 900 (PN 150) Class 1500 (PN 250) Class 2500 (PN 420)						1 2 3 4 5 6 7 8 9					
Materials in plug	Ductile Iron Cast Iron Steel Steel Stainless Steel Special Alloy Steel (To order)							2 4 7 8 9				
Methods of operation	Wrench on both valves								NN			
	Wrench on left valve and gear with vertical handwheel on right valve								NC			
	Wrench on right valve and gear with vertical handwheel on left valve								CN			
	Wrench on left valve and bare stem and flange for actuator on right valve								NL			
	Wrench on right valve and bare stem and flange for actuator on left valve								LN			
	Gear with vertical handwheel on both valves								CC			
	Gear with horizontal handwheel on both valves								DD			
	Gear with vertical handwheel on left valve and gear with horizontal handwheel on right valve								CD			
	Gear with vertical handwheel on right valve and gear with horizontal handwheel on left valve								DC			
	Gear with vertical handwheel on left valve and bare stem and flange for actuator on right valve								CL			
	Gear with vertical handwheel on right valve and bare stem and flange for actuator on left valve								LC			
	Gear with horizontal handwheel on left valve and bare stem and flange for actuator on right valve								DL			
	Gear with horizontal handwheel on right valve and bare stem and flange for actuator on left valve								LD			
	Bare stem and flange for actuator on both valves								LL			
Size of bleed See page A 17	½" ¾" 1" 1½" 2" 2½" 3" The customer specification									- 15 - 20 - 25 - 40 - 50 - 65 - 80 - 90		
Location of bleed	Frontside/operatingside Backside/the opposite side of operatingside										F B	
Bleed connection	Screwed end Flanged End Intergal- Block Flange incl. Stud bolt Clamps End Welding End Socket Welding End Other ends (special end)											0 1 2 4 5 6 9

Example: 55-AP 70199 CL-25F1



CAST IRON

ASTM A 126 Class B (High strength grey iron).

Tensile Strength: min. 31000 PSI (214 N/mm²).

Cast Iron material is very economical and suitable for most common service conditions such as air, water, gas and oil at medium pressure and temperatures. It possesses good resistance to corrosion in most organic solutions, alkalies and many acids of higher concentrations at normal temperatures. Plugs are anti-friction treated with P.T.F.E.

DUCTILE IRON (Cast Iron with spheroidal Graphite).

ASTM A 536 Gr. 60-40-18.

Tensile Strength: min. 60000 PSI (414 N/mm²).

This material is especially used where cast iron does not fulfil the requirements and where cast steel is too expensive. Plugs are anti-friction treated with P.T.F.E.

CARBON STEEL

ASTM A 216 Grade WCB.

Tensile Strength: min. 70000 PSI (485 N/mm²).

PR valves of cast steel are made in accordance with the specification of the mentioned ASTM standard. To counteract seizing steel plugs have a thin coat 20 µm (special tegn, see PDF) of electroless nickel, and then anti-friction treated with P.T.F.E. Carbon steel is suited for valves in cold or hot water applications without corrosive impurities. It is also suitable for oil, gas, air and other line fluids where valves are required of high strength, toughness and stability against vibration, blows and fire, except for extremely high or low temperatures which require steel alloys.

The valves are also available to NACE Standard MR-01-75. Hardness level of Rc 22 or lower.

LEAD-BRONZE 80/10/10

CuPb10Sn10. ISO 1338 – ASTM B30 937.

Tensile Strength: min. 12500 PSI (180 N/mm²).

Brinell hardness: 65

Chemical Properties: Resistant to actions of ordinary services.

Physical Properties: Good pressure tightness and resistant to wear.

Other alloys, fx. 90/10 or 88/10/2,0 are delivered on inquiry.

STAINLESS ACID-RESISTING STEEL

Rust and acid resisting

Chromium

Nickel

Molybdenum

Cr 18% to 21%

9 to 12%

2 to 3

ASTM A 351 Grade CF8M or AISI 316.

Tensile Strength: min. 70000 PSI (485 N/mm²).

To counteract seizing plugs in stainless steel have a thin coat 20 (special tegn, see PDF) electroless nickel, and then anti-friction treated with P.T.F.E.

AUSTENITIC – FERRITIC STEEL (Duplex stainless steel)

ASTM A 890 4A,

Chromium

Nickel

Molybdenum

Nitrogen

Cr 22%

Ni 5%

Mo 2,5%

N 0,1%

Tensile strength: min. 620 N/mm²

The materials A 890 4A are austenitic-ferritic acid-resistant steel with very high mechanical properties. Moreover they are extremely resistant to corrosion.

The materials A 890 4A are very resistant to stress – (SCC) and pitting corrosion in environments containing chloride.

The resistance to stress corrosion (SCC) caused by hydrogen sulphide in environments containing chloride is also excellent. The materials A 890 4A meet the demands usually requiring high alloyed nickel qualities. As the content of chromium and nickel is fairly low these materials will prove an economically good alternative to more expensive high alloyed qualities. To counteract seizing plugs in stainless steel have a thin coat 20 (special tegn, see PDF) electroless nickel, and then anti-friction treated with P.T.F.E.

SPECIAL QUALITIES AND ALLOYS:

Test, which exceeds the requirements of the respective standards, can be carried out on the above mentioned materials if required.

Special alloys are manufactured on request, ect. Super Duplex.



COLOUR CODE

To facilitate identification BCH Valves are normally painted as follows:

Cast Iron: Green	Steel: Blue	Stainless Steel: Silver Grey
Ductile: Dark Grey	Bronze: Unpainted	Duplex: Light Grey

List of standards

The Standards printed in bold print is to be considered as the main standard (specification). The below standards in thin originate from the main standard. Each main standard has its own reference. The list of standard practice is only intended as a guide.

List of Standard Practice	
BS 5353 BS 1560 BS 4504 BS 21 BS 2080 BS 6755	Specification for steel plug valves Circular Flange for Pipes, Valves and Fittings (Class designated) Circular Flange for Pipes, Valves and Fitting (PN designated) Pipe Threads Face-to-Face, Centre-to-Face, End-to-End and Centre-to-End dimensions of valves Testing of Valve Part 1 Specification for production pressure testing requirements.
ASME B 16.34 ASME B 15.6 ASME B 16.11 ASME B 16.25 ASME B 1.20.1 ASME B 16.10	Valves – Flanged, Threaded and Welding Ends Pipe Flanges and Flanged Fittings Forged Fittings, Socket-Welding and Threaded Ends Buttwelding Ends Pipe Threads, General Purpose (Inch) Face-to-Face and End-to-End dimensions of Valves
API 6D ASME B 16.5 ASME B 31.4 ASME B 31.8	Specification for Pipeline Valves (Gate, Plug, Ball and Check Valves) Pipe Flanges and Flanged Fittings Liquid Petroleum Transportation Piping Systems Gas Transmission and Distribution Piping Systems
API 599 API 598 ASME B 16.5 ASME B 16.25 ASME B 16.10 ASME B 16.34	Metal Plug Valves – Flanged and Welding Ends Valve Inspection and Test Pipe Flanges and Flanged Fittings Buttwelding Ends Face-to-Face and End-to-End Dimensions of Valves Valves – Flanged, Threaded and Welding Ends
API 6A	Specification for Wellhead and Christmas Tree Equipment.
Quality management system	Design and manufacture of valves for liquid and gaseous applications on onshore and offshore installation in acc. to Pressure Equipment, Directive 97/23/EC Design and manufacture of valves and associated pipe fittings ISO 9001 American Petroleum institute 6A American Petroleum institute 6D
NACE MR0175	Standard Material Requirements Sulfide Stress Cracking Resistant – Metallic. Materials for Oilfield Equipment. The NACE MR01-75 standard can be connected to every main standard (printed with bold) provided that the choice of material is acceptable to the NACE MR01-75 standard
API 607	Fire Test for Soft-Seated Ball Valves



The simplest method of operating the valve is by using a wrench directly on top of the valve plug.

Straightway valves open and close by rotating through 90°.

The wrench can be fitted on the square of the valve plug in eight different positions. This is a big advantage in places with limited space.

Wrench operation is used on relatively small valve sizes, as indicated on the dimension sheets.

Gear, type C, is enclosed in water-proof casing, with the hand-wheel located vertically on side of the valve. Worm and worm wheel are embedded in heavy bronze bearings, and the axial load stress is absorbed by ball bearings. Both bearings and tooth racks are lubricated with concentrated molybdenum grease to resist high temperatures. (See lubrication of gear, page C4)

Gear, type C, is available in all pressure classes and valve sizes, as indicated on the dimension sheets. Type C can be fitted with electric, pneumatic or hydraulic actuator.

The connection between valve and gear are ISO type.

Gear, type D, is enclosed in water-proof casing, with the hand-wheel located horizontally on top of the valve. Worm and worm wheel are embedded in heavy bronze bearings, and the axial load stress is absorbed by ball bearings. Both bearings and tooth racks are lubricated with concentrated molybdenum grease to resist high temperatures (See lubrication of gear, page C4).

Gear, type D, is available in pressure classes and valve sizes, as indicated on the dimension sheet. Type D can be fitted with electric, pneumatic and hydraulic actuator. The connection between valve and gear are a ISO type.

Gear, type D, is available in pressure classes and valve sizes, as indicated on the dimension sheet. Type D can be fitted with electric, pneumatic and hydraulic actuator.

The connection between valve and gear are a ISO type.



The wrench is available in a short and a long version as type 8K and type 8L.



The gear has fixed stops at extreme position, plus position indicator





METHOD OF OPERATION

Brdr. Christensen Twin Plug Valves are available in a number of possible modes

- 1) Both plugs wrench operated
- 2) One plug wrench, one plug gear operated
- 3) Both plugs gear operated
- 4) Pneumatic, Hydraulic and Electric Actuation on one or both plugs

In addition to the above gearboxes are available in several configurations as well

- A) Vertical handwheel operation
- B) Horizontal handwheel operations
- C) Offset Horizontal Handwheel operation
- D) Offset Horizontal Handwheel operation
- E) Handwheel operation from either side of valve or from the same side of valve

This variety of configurations insures that our design usually fits into the tightest of available spaces.

Customer must advise which above configuration is preferred. Standard configuration is two vertical handwheel when gearboxes are required.



Standard wrench type 8K (Short)

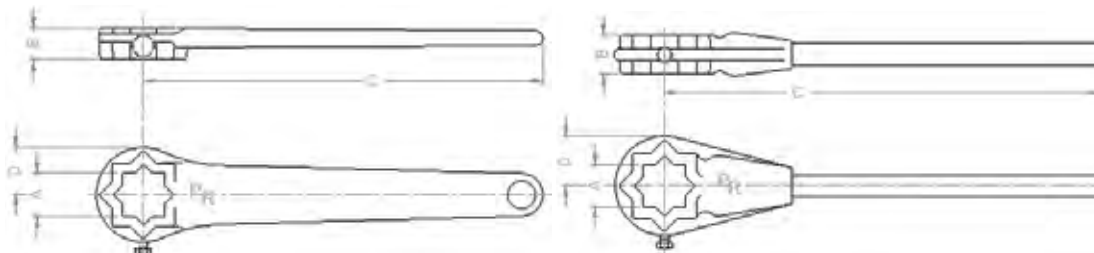

Standard wrench type 2K (Short)

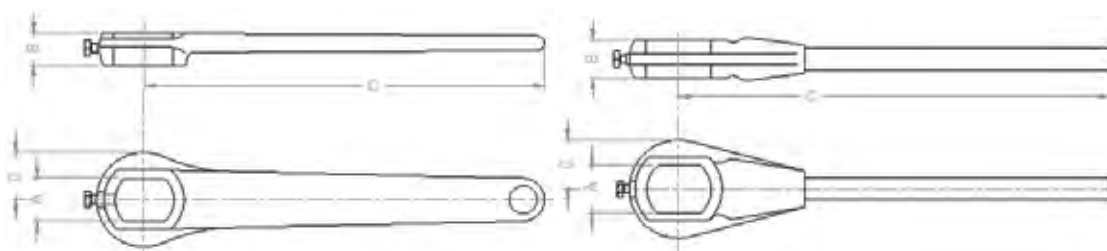

A	B	C	D
17	14	140	20
19	16	150	22
24	18	200	26
27	20	225	30
30	22	280	33
36	26	330	38
50	40	420	52
55	45	815	58
65	50	940	70
70	50	1090	76

Wrench type 8L (Long)

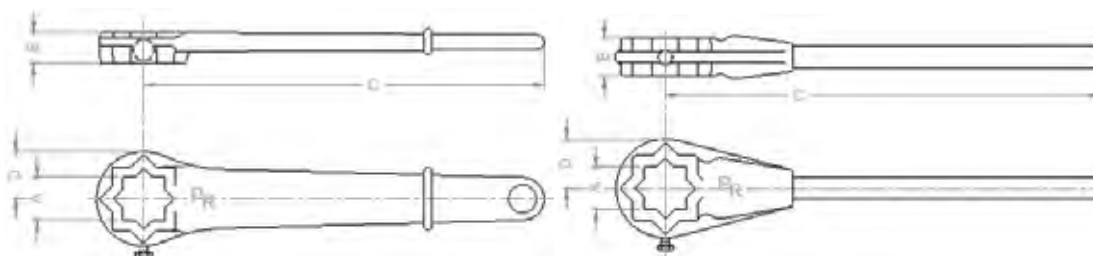

A	B	C	D
17	14	230	20
22	20	300	30
24	20	300	30
27	20	340	30
30	26	420	38
36	26	470	42
41	35	650	50
50	45	815	58
55	50	1090	70
65	50	1270	80



Screwed Ends:

Designed in accordance with API Line
Pipe threads (Taper) API Std. 5B
Table 2.1 or ASME Std. B1.20.1.
Available in size 1/2" to 4"

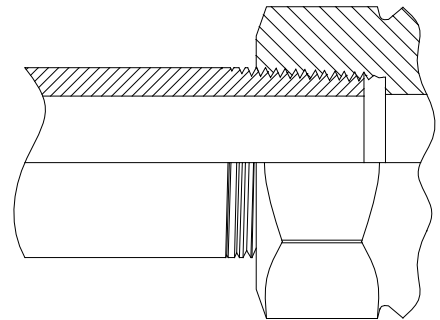

Flanges RF:

Designed in accordance with the ASME B16.5 Standard,
except that two or four of the bolt holes at the lower part of
the flange are threaded. See the dimensions page B1.

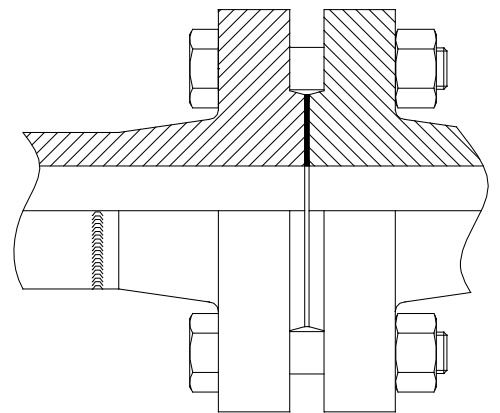

Flanges RJ:

Designed in accordance with the ASME B16.5 Standard,
except that two or four of the bolt holes at the lower part of
the flange are threaded. See the dimensions page B1.

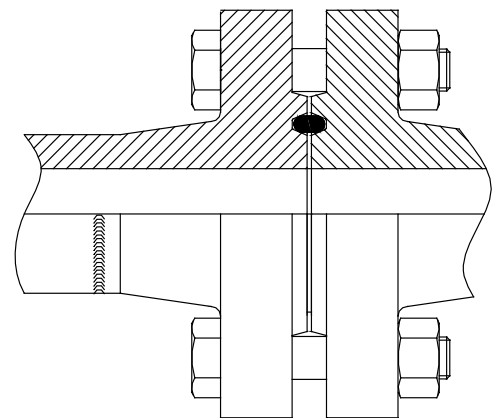

Clamps/hubs:

Designed in accordance with the customer specified
clamps type (For instance grayloc, spo lock, destec,
techlok etc.)

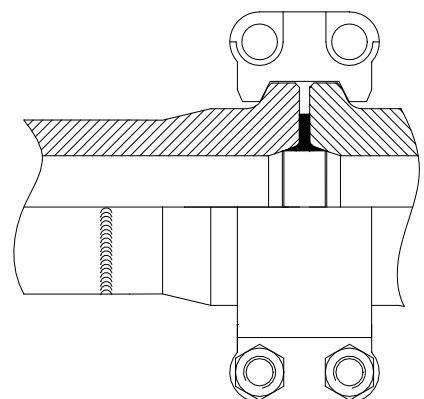



Bleeds and sizes		Code
Standard operation:	Smaller valves have square heads for wrench operation on both valves.	NN
	Larger valves have gear operation with Vertical handwheel on both valves. The front of the valve is the operating side.	CC
Standard size of bleed connection:	Valve: DN 1" Bleed: 1/2" Valve: DN 2" Bleed: 1/2" Valve: DN 3" Bleed: 1/2" Valve: DN 4" Bleed: 3/4" Valve: DN 6" Bleed: 3/4" Valve: DN 8" Bleed: 1" Valve: DN 10" Bleed: 1" Valve: DN 12" Bleed: 1" Valve: DN 14" Bleed: 1 1/2" Valve: DN 16" Bleed: 1 1/2" Valve: DN 18" Bleed: 2" Valve: DN 20" Bleed: 2" Valve: DN 24" Bleed: 2" Bleed: 2 1/2" Bleed: 3"	15 15 15 20 20 25 25 25 40 40 50 50 50 65 80
Standard location of bleed:	On the valve backside = the opposite of operating side. Valve ≤ DN 4" have always lubrication point on the opposite side of the bleed	B
	Frontside/operating side	F
Standard bleed connection:	Screwed (inside thread API) Valve size ≤ 12"	0
	Flanged RF Valve size ≥ 14"	1

NB. When requirements are different from the BCH standard, please advise at inquiry or order stage.

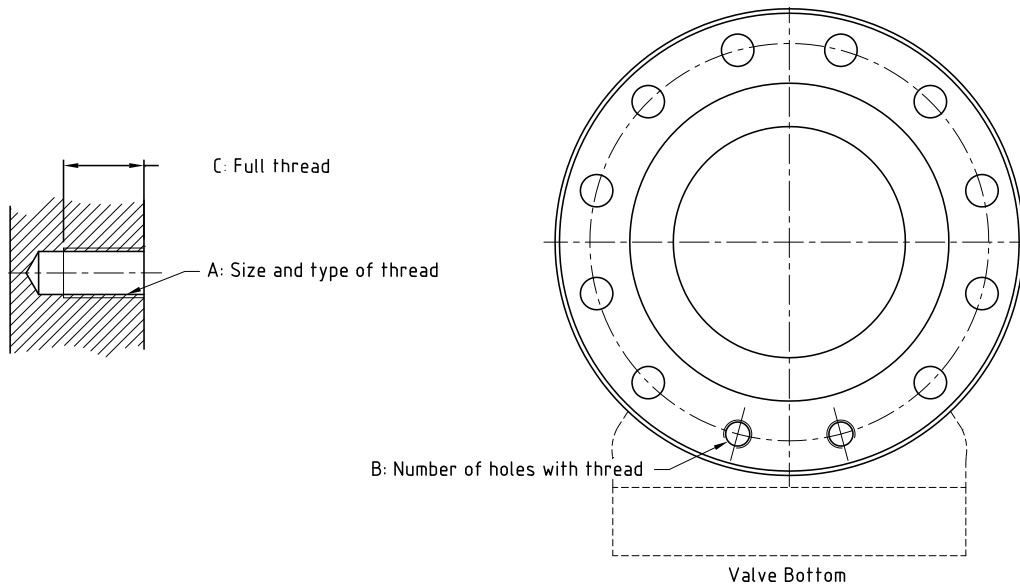

In each connection flange									
Valve size	Class 150			Class 300			Class 600		
DN	A	B	C	A	B	C	A	B	C
1"	1/2" UNC	2 of 4	15 mm	5/8" UNC	2 of 4	19 mm	5/8" UNC	2 of 4	19 mm
1 1/2"							3/4" UNC	4 of 4	20 mm
2"	5/8" UNC	2 of 4	15 mm	5/8" UNC	2 of 8	19 mm	5/8" UNC	2 of 8	19 mm
3"	5/8" UNC	2 of 4	19 mm	3/4" UNC	2 of 8	22 mm	3/4" UNC	2 of 8	22 mm
4"	No threaded holes			No threaded holes			7/8" UNC	2 of 8	25 mm
6"	3/4" UNC	2 of 8	22 mm	3/4" UNC	2 of 12	22 mm	1" UNC	4 of 12	30 mm
8"	3/4" UNC	2 of 8	22 mm	7/8" UNC	2 of 12	25 mm	1 1/8" 8UN	4 of 12	30 mm
10"	7/8 UNC	2 of 12	25 mm	1" UNC	4 of 16	30 mm	1 1/4" 8UN	4 of 20	38 mm
12"		2 of 12	25 mm	1 1/8" 8UN	2 of 16	30 mm	1 1/4" 8UN	4 of 20	38 mm
14"				1 1/8" 8UN	4 of 20	30 mm	1 3/8" 8UN	4 of 20	42 mm
16"	1" UNC	2 of 16	30 mm	1 1/4" 8UN	4 of 20	38 mm	1 1/2" 8UN	4 of 20	46 mm
18"	1 1/8" 8UN	2 of 16	29 mm	1 1/4" 8UN	2 of 24	32 mm	1 5/8" 8UN	4 of 20	49 mm
20"				1 1/4" 8UN	4 of 24	38 mm	1 5/8" 8UN	4 of 24	49 mm
24"				1 1/2" 8UN	4 of 24	40 mm	1 7/8" 8UN	6 of 24	56 mm

In each connection flange									
Valve size	Class 900			Class 1500			Class 2500		
DN	A	B	C	A	B	C	A	B	C
1"	7/8" UNC	4 of 4	25 mm	7/8" UNC	4 of 4	25 mm			
2"	7/8" UNC	2 of 8	25 mm	7/8" UNC	2 of 8	25 mm	1" UNC	2	33 mm
3"	7/8" UNC	2 of 8	25 mm	1 1/8" 8NC	2 of 8	30 mm	1 1/4" 8UN	2	38 mm
4"	1 1/8" 8UN	2 of 8	30 mm	1 1/4" 8NC	2 of 8	38 mm	1 1/2" 8UN	2	46 mm
6"	1 1/8" 8UN	2 of 12	30 mm	1 3/8" 8NC	4 of 12	42 mm	2" 8UN	2	61 mm
8"	1 3/8" 8UN	2 of 12	42 mm	1 5/8" 8NC	2 of 12	49 mm	2" 8UN	4	61 mm
10"	1 3/8" 8UN	4 of 16	42 mm	1 7/8" 8NC	2 of 12	57 mm	2 1/2" 8UN	4	76 mm
12"	1 3/8" 8UN	4 of 20	42 mm	2" 8UN	4* of 16	61 mm			
14"	1 1/2" 8UN	4 of 20	46 mm	2 1/4" 8UN	2 of 16	68 mm			
16"	1 5/8" 8UN	4 of 20	49 mm	2 1/2" 8UN	4 of 16	76 mm			
20"	2" 8UN	4 of 20	61 mm						

* + 2 threaded holes at the top of the valve



Class	Max CWP	Test Pressure	Pattern	Connections	Port	Materials	
						Body & Cover	Plug
150	285 Psi	Shell 450 Psi Seat 515 Psi	Straightway	Flanges R.F or R.J. ASME B 16.5 Face to Face See column V Bleed: See Data Sheet or specified by purchaser	Rectangular	Cast Steel ASTM A 216 Grade WCB Cover: EN 10025-2 S355J2	Cast Iron ASTM A 126 Class B Steel

<p>Operation: Manual by wrench. Type 8K.</p>		<p>Operation: Bare stem with mounting flange for actuation. "ISO 5211"</p>		<p>Operation: Manual worm gear with vertical handwheel.</p>	
Plug	DN 1" – 6"	DN 1" – 20"	DN 1" – 4"		
Cast Iron	55-AP 70124 NN-XXXX	55-AP 70124 LL-XXXX	55-AP 70124 CC-XXXX		
Steel	55-AP 70127 NN-XXXX	55-AP 70127 LL-XXXX	55-AP 70127 CC-XXXX		

XXXX: See data sheet page 12 or code sheet page 5

DN	A	B	C	D	E	F	H	I	J	K	L	M	N	Q	R	V	V	Raised Face	Ring Joint	ISO Flange 5211
1"	52	88	138	100	89	30	300	124/209	32	40	130	132	50	25	108	229	229		F07	
2"	65	106	158	115	110	30	300	124/209	32	40	151	132	50	51	152	267	279		F07	
3"	80	142	190	165	131	36	300	124/209	32	40	172	132	50	76	191	343	355		F07	
4"	86	158	224	170	154	50	300	124/209	32	40	195	132	50	102	229	432	445		F10	
6"	116	213	282	232	215	55								152	279	546	558		F14	
8"	147	240		270	249									203	343	622	635		F14	
10"	150	266		296	277									254	406	661	674		F14	
12"	175	303		340	309									305	483	762	774		F16	
14"	202	334		380	351									337	533	889	902		F25	
16"	230	356		415	386									387	597	991	1004		F25	
18"	257	426		450	450									438	635	1092	1104		F30	
20"	284	471		494	503									489	699	1194	1209		F30	



Class	Max CWP	Test Pressure	Pattern	Connections	Port	Materials	
						Body & Cover	Plug
150	285 Psi	Shell 450 Psi Seat 315 Psi	Straightway	Flanges R.F or R.J. ASME B 16.5 Face to Face See column V Bleed: See Data Sheet or specified by purchaser	Rectangular	Cast Steel ASTM A 216 Grade WCB Cover: EN 10025-2 S355 J2	Cast Iron ASTM A 126 Class B Steel

Operation: Manual worm gear with vertical handwheel CC		Operation: Manual worm gear with horizontal handwheel DD		Operation: Manual worm gear with one horizontal handwheel and one vertical handwheel DC	
Plug	DN 6" – 20"	DN 6" – 20"	DN 6" – 20"	DN 6" – 20"	DN 6" – 20"
Cast Iron	55-AP 70124 CC-XXXX	55-AP 70124 DD-XXXX	55-AP 70124 DD-XXXX	55-AP 70124 DC-XXXX	55-AP 70124 DC-XXXX
Steel	55-AP 70127 CC-XXXX	55-AP 70127 DD-XXXX	55-AP 70127 DD-XXXX	55-AP 70127 DC-XXXX	55-AP 70127 DC-XXXX

XXXX: See data sheet page 12 or code sheet page 5

DN	A	B	D	H	I	J	L	M	N	O	P	Q	R	Raised Face V	Ring Joint V
6"	116	213	232	400	101/201	38	314	205	85	46	374	152	279	546	558
8"	147	240	270	400	101/201	38	350	205	85	46	409	203	343	622	635
10"	150	266	296	400	101/201	38	378	205	85	46	438	254	406	661	674
12"	175	303	340	600	101/201	38	420	230	95	70	479	305	483	762	774
14"	202	334	380	600	101/201	38	506	298	135	69	577	337	533	889	902
16"	230	356	415	600	101/201	38	541	298	135	69	612	387	597	991	1004
18"	257	426	450	600	101/201	38	580	337	160	108	650	438	635	1092	1104
20"	284	471	494	600	101/201	38	659	337	160	108	729	489	699	1194	1206



Class	Max CWP	Test Pressure	Pattern	Connections	Port	Materials	
						Body & Cover	Plug
300	740 Psi	Shell 1125 Psi Seat 815 Psi	Straightway	Flanges R.F or R.J. ASME B 16.5 Face to Face See column V Bleed: See Data Sheet or specified by purchaser	Rectangular	Cast Steel ASTM A 216 Grade WCB Cover: EN 10025-2 S355 J2	Cast Iron ASTM A 126 Class B Steel

<p>Operation: Manual by wrench. Type 8K</p>		<p>Operation: Bare stem with mounting flange for actuation. "ISO 5211"</p>		<p>Operation: Manual worm gear with vertical handwheel.</p>	
Plug	DN 1" - 6"		DN 1" - 20"		DN 1" - 4"
Cast Iron			55-AP 70144 LL-XXXX		
Steel	55-AP 70147 NN-XXXX		55-AP 70147 LL-XXXX		55-AP 70147 CC-XXXX

XXXX: See data sheet page 12 or code sheet page 5

DN	A	B	C	D	E	F	H	I	J	K	L	M	N	Q	R	V	V	ISO Flange 5211
1"	52	88	138	100	89	30	300	124/209	32	40	130	132	50	25	124	229	229	F07
2"	65	106	158	115	110	30	300	124/209	32	40	151	132	50	51	165	283	299	F07
3"	80	142	190	165	131	36	300	124/209	32	40	172	132	50	76	210	387	403	F10
4"	86	158	224	170	154	50	300	124/209	42	49	195	165	63	102	254	457	473	F10
6"	116	213	282	232	215	55								152	318	559	575	F14
8"	147	240		270	249									203	381	686	702	F14
10"	186	312		360	306									254	445	826	842	F16
12"	175	303		340	309									305	521	838	854	F16
14"	202	334		380	351									337	584	889	905	F25
16"	230	356		415	386									387	648	991	1006	F25
18"	257	426		516	424									432	711	1092	1108	F30
20"	284	471		530	503									483	775	1194	1213	F30

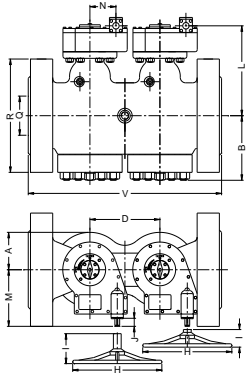
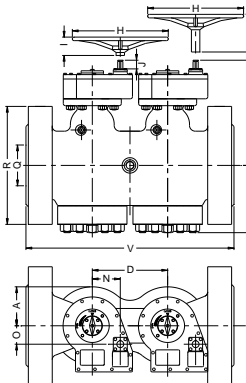
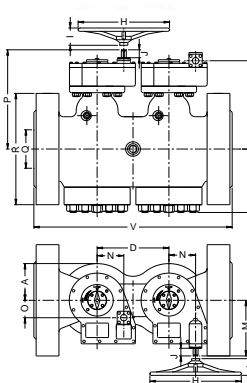

Class	Max CWP	Test Pressure	Pattern	Connections	Port	Materials	
						Body & Cover	Plug
300	740 Psi	Shell 1125 Psi Seat 815 Psi	Straightway	Flanges R.F or R.J. ASME B 16.5 Face to Face See column V Bleed: See Data Sheet or specified by purchaser	Rectangular	Cast Steel ASTM A 216 Grade WCB	Cast Iron ASTM A 126 Class B
						Cover: EN 10025-2 S355 J2	Steel

<p>Operation: Manual worm gear with vertical handwheel CC</p> 		<p>Operation: Manual worm gear with horizontal handwheel DD</p> 		<p>Operation: Manual worm gear with one horizontal handwheel and one vertical handwheel DC</p> 	
Plug	DN 6" - 20"	DN 6" - 20"	DN 6" - 20"	DN 6" - 20"	DN 6" - 20"
Cast Iron	55-AP 70144 CC-XXXX	55-AP 70144 DD-XXXX	55-AP 70144 DD-XXXX	55-AP 70144 DC-XXXX	55-AP 70144 DC-XXXX
Steel	55-AP 70147 CC-XXXX	55-AP 70147 DD-XXXX	55-AP 70147 DD-XXXX	55-AP 70147 DC-XXXX	55-AP 70147 DC-XXXX

XXXX: See data sheet page 12 or code sheet page 5

DN	A	B	D	H	I	J	L	M	N	O	P	Q	R	Raised Face V	Ring Joint V
6"	116	213	232	400	101/201	38	314	205	85	46	374	152	318	559	575
8"	147	240	270	400	101/201	38	350	205	85	46	409	203	381	686	702
10"	186	312	360	600	101/201	38	417	230	95	70	477	254	445	826	842
12"	175	303	340	600	101/201	38	420	230	95	70	479	305	521	838	854
14"	202	334	380	600	101/201	38	506	298	135	69	577	337	584	889	905
16"	230	356	415	600	101/201	38	541	298	135	69	612	387	648	991	1006
18"	257	426	450	600	101/201	38	580	337	160	108	650	432	711	1092	1108
20"	284	471	494	600	101/201	38	659	337	160	108	729	483	775	1194	1213



Class	Max CWP	Test Pressure	Pattern	Connections	Port	Materials	
						Body & Cover	Plug
600	1480 Psi	Shell 2225 Psi Seat 1630 Psi	Straight-way	Flanges R.F or R.J. ASME B 16.5 Face to Face to ASME B 16.10 Regular and Venturi Pattern Bleed: See Data Sheet or specified by purchaser	Rectangular	Cast Steel ASTMA 216 Grade WCB Cover: EN 10025-2 S355 J2	Cast Iron ASTMA 126 Class B Steel

<p>Operation: Manual by wrench. Type 8L</p>		<p>Operation: Bare stem with mounting flange for actuation. "ISO 5211"</p>		<p>Operation: Manual worm gear with vertical handwheel.</p>	
Plug	DN 1" - 4"	DN 1" - 24"	DN 1" - 4"		
Cast Iron	55-AP 70164 NN-XXXX	55-AP 70164 LL-XXXX	55-AP 70164 CC-XXXX		
Steel	55-AP 70167 NN-XXXX	55-AP 70167 LL-XXXX	55-AP 70167 CC-XXXX		

XXXX: See data sheet page A12 or code sheet page A5

DN	A	B	C	D	E	F	H	I	J	K	L	M	N	Q	R	V	V	ISO Flange 5211
1"	52	88	138	100	89	30	300	124/209	32	40	130	132	50	25	124	*254	*254	F07
2"	65	109	158	115	110	30	300	124/209	32	40	151	132	50	51	165	292	295	F07
3"	76	146	198	137	139	36	300	124/209	32	40	182	132	50	76	210	356	359	F10
4"	95	167	242	170	169	55	300	124/209	42	49	215	165	63	102	273	432	435	F12
6"	123	219		232	219									152	356	559	562	F14
8"	152	256		264	260									200	419	660	664	**F16
10"	172	286		320	281									248	508	787	791	F25
12"	184	326		343	359									299	559	838	841	F25
14"	202	345		380	363									327	603	889	892	F30
16"	230	383		415	385									375	686	991	994	F30
18"	257	440		450	487									419	743	1092	1095	F35
20"	284	476		494	504									464	813	1194	1200	F35
24"	336	566		600	580									559	940	1397	1407	F35

Note: *Not included in the standards.

** With C- and D-gear, the ISO topwork is not according to this size



Class	Max CWP	Test Pressure	Pattern	Connections	Port	Materials	
						Body & Cover	Plug
600	1480 Psi	Shell 2225 Psi Seat 1630 Psi	Straightway	Flanges R.F or R.J. ASME B 16.5 Face to Face acc. to ASME B 16.10 Regular and Venturi Pattern Bleed: See Data Sheet or specified by purchaser	Rectangular	Cast Steel ASTMA 216 Grade WCB Cover: EN 10025-2 S355 J2	Cast Iron ASTMA 126 Class B
							Steel

Operation: Manual worm gear with vertical handwheel CC		Operation: Manual worm gear with horizontal handwheel DD		Operation: Manual worm gear with one horizontal handwheel and one vertical handwheel DC	
Plug	DN 6" - 24"	DN 6" - 24"	DN 6" - 24"	DN 6" - 24"	DN 6" - 24"
Cast Iron	55-AP 70164 CC-XXXX	55-AP 70164 DD-XXXX	55-AP 70164 DD-XXXX	55-AP 70164 DC-XXXX	55-AP 70164 DC-XXXX
Steel	55-AP 70167 CC-XXXX	55-AP 70167 DD-XXXX	55-AP 70167 DD-XXXX	55-AP 70167 DC-XXXX	55-AP 70167 DC-XXXX

XXXX: See data sheet page 12 or code sheet page 5

														Raised Face	Ring Joint
DN	A	B	D	H	I	J	L	M	N	O	P	Q	R	V	V
6"	123	219	232	400	101/201	38	316	205	85	46	376	152	356	559	562
8"	152	256	264	400	101/201	38	358	205	85	46	418	200	419	660	664
10"	172	286	320	500	101/201	38	392	230	95	70	453	248	508	787	791
12"	184	326	343	600	101/201	38	486	298	135	69	557	299	559	838	841
14"	202	345	380	600	101/201	38	506	298	135	69	577	327	603	889	892
16"	230	383	415	600	101/201	38	542	337	160	108	613	375	686	991	994
18"	257	440	450	700	101/201	38	625	360	175	130	696	419	743	1092	1095
20"	284	476	494	700	101/201	38	659	360	175	130	730	464	813	1194	1200
24"	336	566	600	700	101/201	38	738	438	200	210	809	559	940	1397	1407



Class	Max CWP	Test Pressure	Pattern	Connections	Port	Materials	
						Body & Cover	Plug
900	2220 Psi	Shell 3350 Psi Seat 2442 Psi	Straightway	Flanges R.F or R.J. ASME B 16.5 Face to Face acc. to ASME B16.10 Regular and Venturi Pattern Bleed: See Data Sheet or specified by purchaser	Rectangular	Cast Steel ASTM A 216 Grade WCB Cover: EN 10025-2 S355 J2	Cast Iron ASTM A 126 Class B Steel

<p>Operation: Manual by wrench. Type 8L</p>	<p>Operation: Bare stem with mounting flange for actuation. "ISO 5211"</p>	<p>Operation: Manual worm gear with vertical handwheel.</p>	
Plug	DN 1" - 3"	DN 1" - 18"	DN 1" - 4"
Cast Iron	55-AP 70174 NN-XXXX	55-AP 70174 LL-XXXX	55-AP 70174 CC-XXXX
Steel	55-AP 70177 NN-XXXX	55-AP 70177 LL-XXXX	55-AP 70177 CC-XXXX

XXXX: See data sheet page 12 or code sheet page 5

DN	A	B	C	D	E	F	H	I	J	K	L	M	N	Q	R	Raised Face	Ring Joint	ISO Flange 5211
1"	56	97	139	90	89	30								22	150	254	254	F07
2"	76	125	175	145	124	30	300	124/209	32	40	165	132	50	48	216	368	372	F10
3"	82	135	204	145	137	41	300	124/209	32	40	178	132	50	73	241	381	384	F10
4"	96	172	245	175	170	50	300	124/209	42	49	216	165	63	98	292	457	460	F12
6"	127	217		245	219									146	381	610	613	F14
8"	158	258		305	276									191	470	737	740	F16
10"	184	303		340	306									238	546	838	841	F25
12"	208	356		400	350									283	610	965	968	F30
14"	235	395		416	403									311	641	*1029	*1038	F30
16"	260	452		464	434									356	705	1130	1140	F35
18"	312	526		540	487									400	787	*1219	*1232	F35

Note: *Not included in the standards.



Class	Max CWP	Test Pressure	Pattern	Connections	Port	Materials	
						Body & Cover	Plug
900	2220 Psi	Shell 3350 Psi Seat 2442 Psi	Straightway	Flanges R.F or R.J. ASME B 16.5 Face to Face acc. to ASME B16.10 Regular and Venturi Pattern Bleed: See Data Sheet or specified by purchaser	Rectangular	Cast Steel ASTM A 216 Grade WCB Cover: EN 10025-2 S355 J2	Cast Iron ASTM A 126 Class B Steel

Operation: Manual worm gear with vertical handwheel CC,		Operation: Manual worm gear with horizontal handwheel DD,		Operation: Manual worm gear with one horizontal handwheel and one vertical handwheel DC,	
Plug	DN 6" - 18"	DN 6" - 18"	DN 6" - 18"	DN 6" - 18"	DN 6" - 18"
Cast Iron	55-AP 70174 CC-XXXX	55-AP 70174 DD-XXXX	55-AP 70174 DD-XXXX	55-AP 70174 DC-XXXX	55-AP 70174 DC-XXXX
Steel	55-AP 70177 CC-XXXX	55-AP 70177 DD-XXXX	55-AP 70177 DD-XXXX	55-AP 70177 DC-XXXX	55-AP 70177 DC-XXXX

XXXX: See data sheet page 12 or code sheet page 5

DN	A	B	D	H	I	J	L	M	N	O	P	Q	R	Raised Face V	Ring Joint V
6"	127	216	245	400	101/201	38	320	205	85	46	380	146	381	610	613
8"	158	258	305	500	101/201	38	386	230	95	70	447	191	470	737	740
10"	184	303	340	600	101/201	38	461	298	135	69	532	238	546	838	841
12"	208	356	400	600	101/201	38	505	337	160	108	576	283	610	965	968
14"	235	395	416	600	101/201	38	558	337	160	108	629	311	641	*1029	*1038
16"	260	452	464	700	101/201	38	589	360	175	130	660	356	705	1130	1140
18"	312	526	540	700	101/201	38	642	397	176	168	713	400	787	*1219	*1232

Note: *Not included in the standards.



Class	Max CWP	Test Pressure	Pattern	Connections	Port	Materials	
						Body & Cover	Plug
1500	3705 Psi	Shell 5575 Psi Seat 4075 Psi	Straightway	Flanges R.F or R.J. ASME B 16.5 Face to Face acc. to ASME B16.10 Regular and Venturi Pattern Bleed: See Data Sheet or specified by purchaser	Rectangular	Cast Steel ASTM A 216 Grade WCB Cover: EN 10025-2 S355 J2	Cast Iron ASTM A 126 Class B Steel

<p>Operation: Manual by wrench. Type 8L.</p>	<p>Operation: Bare stem with mounting flange for actuation. "ISO 5211"</p>	<p>Operation: Manual worm gear with vertical handwheel.</p>	
Plug	DN 1" - 3"	DN 1" - 18"	DN 1" - 4"
Cast Iron	55-AP 70184 NN-XXXX	55-AP 70184 LL-XXXX	55-AP 70184 CC-XXXX
Steel	55-AP 70187 NN-XXXX	55-AP 70187 LL-XXXX	55-AP 70187 CC-XXXX

XXXX: See data sheet page A12 or code sheet page A5

DN	A	B	C	D	E	F	H	I	J	K	L	M	N	Q	R	Raised Face	Ring Joint	ISO Flange 5211
																V	V	
1"	56	97	137	90	89	30								22	150	254	254	F07
2"	76	125	174	145	124	30	300	124/209	32	40	165	132	50	48	216	368	371	F10
3"	99	170	220	182	147	50	300	124/209	42	49	193	165	63	70	267	470	473	F12
4"	103	180		235	180		300	124/209	42	49	226	165	63	92	311	546	549	F12
6"	143	255		260	237									137	394	705	711	**F16
8"	169	312		300	263									178	483	832	842	**F25
10"	208	364		380	320									222	584	991	1000	F25
12"	243	419		452	397									264	673	1130	1146	F30
14"	243	419		492	411									289	749	*1257	*1276	F30
16"	285	498		560	466									330	826	1384	1407	F35
18"	315	561		640	526									372	914	*1537	*1559	F35

Note: *Not included in the standards.

**With C and D-gear the ISO topworks is not according to this size.

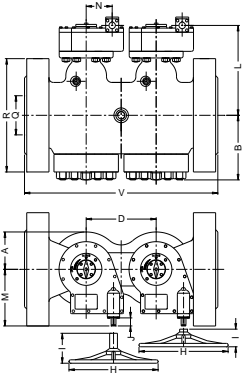
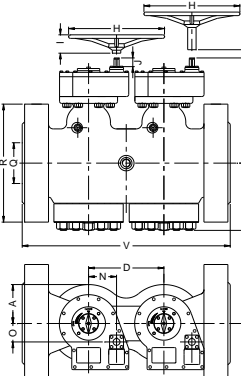
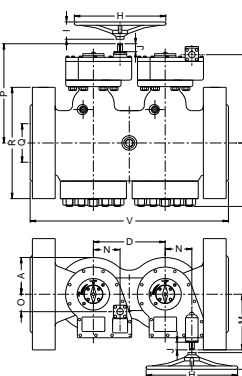

Class	Max CWP	Test Pressure	Pattern	Connections	Port	Materials	
						Body & Cover	Plug
1500	3705 Psi	Shell 5575 Psi Seat 4075 Psi	Straightway	Flanges R.F or R.J. ASME B 16.5 Face to Face acc. to ASME B16.10 Regular and Venturi Pattern Bleed: See Data Sheet or specified by purchaser	Rectangular	Cast Steel ASTM A 216 Grade WCB Cover: EN 10025-2 S355 J2	Cast Iron ASTM A 126 Class B Steel

<p>Operation: Manual worm gear with vertical handwheel CC,</p> 		<p>Operation: Manual worm gear with horizontal handwheel DD,</p> 		<p>Operation: Manual worm gear with one horizontal handwheel and one vertical handwheel DC,</p> 	
Plug	DN 6" - 18"	DN 6" - 18"	DN 6" - 18"	DN 6" - 18"	DN 6" - 18"
Cast Iron	55-AP 70184 CC-XXXX	55-AP 70184 DD-XXXX	55-AP 70184 DD-XXXX	55-AP 70184 DC-XXXX	55-AP 70184 DC-XXXX
Steel	55-AP 70187 CC-XXXX	55-AP 70187 DD-XXXX	55-AP 70187 DD-XXXX	55-AP 70187 DC-XXXX	55-AP 70187 DC-XXXX

XXXX: See data sheet page 12 or code sheet page 5

DN	A	B	D	H	I	J	L	M	N	O	P	Q	R	V	Ring Joint
6"	143	255	260	400	101	38	338	205	85	46	398	137	394	705	711
8"	169	312	300	500	101	38	373	230	95	70	434	178	483	832	842
10"	208	364	380	600	101	38	477	298	135	69	548	222	584	991	1000
12"	243	419	452	600	101	38	552	337	160	108	623	264	673	1130	1146
14"	243	419	492	600	101	38	561	337	160	108	632	289	749	*1257	*1276
16"	276	498	560	700	101	38	621	397	176	168	692	330	826	1384	1407
18"	315	561	640	700	101	38	710	438	200	210	783	372	914	*1537	*1559

Note: *Not included in the standards.



Class	Max CWP	Test Pressure	Pattern	Connections	Port	Materials	
						Body & Cover	Plug
2500	6170 Psi	Shell 9275 Psi Seat 6787 Psi	Straightway	Flanges R.F or R.J. ASME B 16.5 Face to Face acc. to ASME B16.10 Regular Pattern Bleed: See Data Sheet or specified by purchaser	Rectangular	Cast Steel ASTM A 216 Grade WCB Cover: EN 10025-2 S355 J2	Cast Iron ASTM A 126 Class B Steel

<p>Operation: Manual by wrench. Type 8L.</p>		<p>Operation: Bare stem with mounting flange for actuation. "ISO 5211".</p>		<p>Operation: Manual worm gear with vertical handwheel.</p>	
Plug	DN 2" - 3"	DN 2" - 16"	DN 2" - 3"		
Cast Iron	55-AP 70194 NN-XXXX	55-AP 70194 LL-XXXX	55-AP 70194 CC-XXXX		
Steel	55-AP 70197 NN-XXXX	55-AP 70197 LL-XXXX	55-AP 70197 CC-XXXX		

XXXX: See data sheet page 12 or code sheet page 5

DN	A	B	C	D	E	F	H	I	J	K	L	M	N	Q	R	V	V	ISO Flange 5211
2"	87	155	200	170	134	41	300	124/209	42	49	177	165	63	38	235	451	454	F10
3"	110	188	232	210	159	50	300	124/209	42	49	205	165	63	57	305	578	584	F12
4"	122	219		258	200									73	356	673	683	F14
6"	164	278		320	228									111	483	914	927	F16
8"	208	404		372	300									146	553	1022	1038	F25
10"	254	498		460	376									184	673	1270	1292	F30
12"	280	510		565	397									219	762	1422	1445	F35
14"	300	535		625	416									242	*	*1400	*1400	F35
16"	300	535		625	416									276	*	*1400	*1400	F35

Note: *Not included in the standards.



Class	Max CWP	Test Pressure	Pattern	Connections	Port	Materials	
						Body & Cover	Plug
2500	6170 Psi	Shell 9275 Psi Seat 6787 Psi	Straightway	Flanges R.F or R.J. ASME B 16.5 Face to Face acc. to ASME B16.10 Regular Pattern Bleed: See Data Sheet or specified by purchaser	Rectangular	Cast Steel ASTM A 216 Grade WCB Cover: EN 10025-2 S355 J2	Cast Iron ASTM A 126 Class B
							Steel

<p>Operation: Manual worm gear with vertical handwheel CC.</p>		<p>Operation: Manual worm gear with horizontal handwheel DD.</p>		<p>Operation: Manual worm gear with one horizontal handwheel and one vertical handwheel DC.</p>	
Plug	DN 4" - 16"	DN 4" - 16"	DN 4" - 16"	DN 4" - 16"	DN 4" - 16"
Cast Iron	55-AP 70194 CC-XXXX	55-AP 70194 DD-XXXX	55-AP 70194 DC-XXXX	55-AP 70194 CC-XXXX	55-AP 70194 DC-XXXX
Steel	55-AP 70197 CC-XXXX	55-AP 70197 DD-XXXX	55-AP 70197 DC-XXXX	55-AP 70197 CC-XXXX	55-AP 70197 DC-XXXX

XXXX: See data sheet page 12 or code sheet page 5

														Raised Face	Ring Joint
DN	A	B	D	H	I	J	L	M	N	O	P	Q	R	V	V
4"	122	219	258	400	101/201	38	301	205	85	46	361	73	356	673	683
6"	164	278	320	500	101/201	38	338	230	95	70	399	111	483	914	927
8"	208	404	372	600	101/201	38	455	298	135	69	526	146	553	1022	1038
10"	254	498	460	600	101/201	38	531	337	160	108	602	184	673	1270	1292
12"	280	510	565	700	101/201	38	552	360	175	130	623	219	762	1422	1445
14"	300	535	625	700	101/201	38	572	397	176	168	641	242	*	*1400	*1400
16"	300	535	625	700	101/201	38	572	397	176	168	641	276	*	*1400	*1400

Note: *Not included in the standards.



STRAIGHTWAY
TAPER TWIN PLUG VALVES

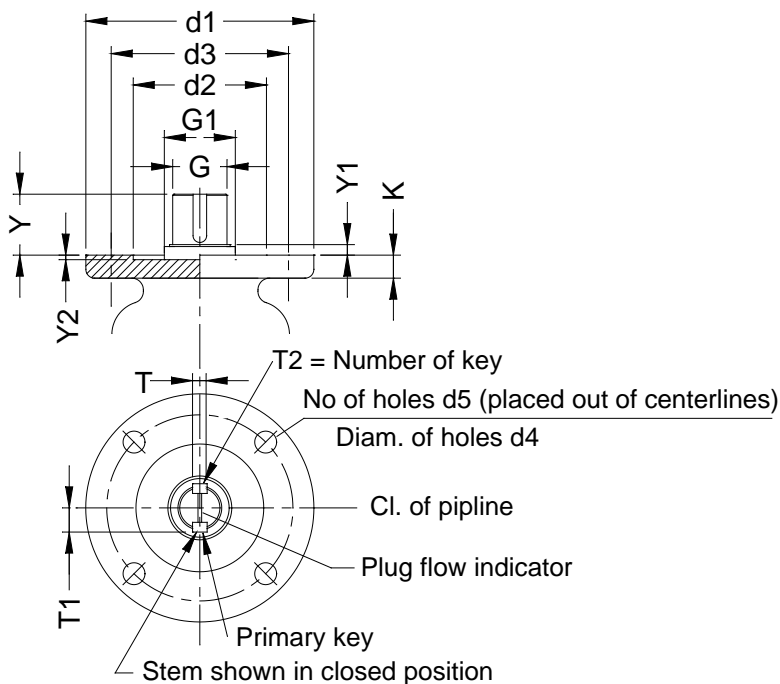

Class 150															
DN	ISO	$d1$	$d2$	$d3$	$d4$	$d5$	G	$G1$	K	T	$T1$	$T2$	Y	$Y1$	$Y2$
1"	F07	90	55	70	9	4	20	32	11	6	12,5	1	34	7,5	3,5
2"	F07	90	55	70	9	4	24	35	11	8	15	1	46	7	3,5
3"	F07	90	55	70	9	4	30	42	11	8	18	1	47	8,5	3,5
4"	F10	125	70	102	11	4	34	47	12	10	20	1	57	8,5	3,5
6"	F12	150	85	125	13	4	50	67	13	14	28,5	1	67	8,5	3,5
8"	F14	175	100	140	18	4	60	78	17	18	34	1	78	11	4,5
10"	F16	210	130	165	22	4	68	86	22	20	38,5	1	79	10,5	5,5
12"	F16	210	130	165	22	4	68	86	22	20	38,5	2	92	10,5	5,5
14"	F16	210	130	165	22	4	-	-	22	-	-	-	-	-	5,5
16"	F25	300	200	254	18	8	-	-	27	-	-	-	-	-	5,5
18"	F25	300	200	254	18	8	-	-	27	-	-	-	-	-	5,5
20"	F25	300	200	254	18	8	-	-	27	-	-	-	-	-	5,5

Class 300															
DN	ISO	$d1$	$d2$	$d3$	$d4$	$d5$	G	$G1$	K	T	$T1$	$T2$	Y	$Y1$	$Y2$
1"	F07	90	55	70	9	4	20	32	11	6	12,5	1	34	7,5	3,5
2"	F07	90	55	70	9	4	24	35	11	8	15	1	46	7	3,5
3"	F10	125	70	102	11	4	30	42	12	8	18	1	57	8,5	3,5
4"	F10	125	70	102	11	4	34	47	12	10	20	1	57	8,5	3,5
6"	F14	175	100	140	18	4	50	67	17	14	28,5	2	77	8,5	4,5
8"	F14	175	100	140	18	4	60	78	17	18	34	1	78	11	4,5
10"	F16	210	130	165	22	4	68	86	22	20	38,5	2	92	10,5	5,5
12"	F16	210	130	165	22	4	68	86	22	20	38,5	2	92	10,5	5,5
14"	F25	300	200	254	18	8	-	-	27	-	-	-	-	-	5,5
16"	F25	300	200	254	18	8	-	-	27	-	-	-	-	-	5,5
18"	F30	350	230	298	22	8	-	-	32	-	-	-	-	-	5,5
20"	F30	350	230	298	22	8	-	-	32	-	-	-	-	-	5,5



STRAIGHTWAY
TAPER TWIN PLUG VALVES

Class 600															
DN	ISO	d1	d2	d3	d4	d5	G	G1	K	T	T1	T2	Y	Y1	Y2
1"	F07	90	55	70	9	4	20	32	11	6	12,5	1	34	7,5	3,5
2"	F07	90	55	70	9	4	24	35	11	8	15	1	46	7	3,5
3"	F10	125	70	102	11	4	30	42	12	8	18	1	57	8,5	3,5
4"	F12	150	85	125	13	4	40	53	13	12	23	1	67	7,5	3,5
6"	F14	175	100	140	18	4	50	67	17	14	28,5	2	77	8,5	4,5
8"	F16	210	130	165	22	4	60	78	22	18	34	1	88	10	5,5
10"	F25	300	200	254	18	8	68	86	27	20	38,5	2	92	10,5	5,5
12"	F25	300	200	254	18	8	82	105	27	22	46	2	108	10,5	5,5
14"	F30	350	230	298	22	8	82	105	32	22	46	2	108	10,5	5,5
16"	F30	350	230	298	22	8	82	105	32	22	46	2	108	10,5	5,5
18"	F35	415	260	356	33	8	90	120	37	25	50	2	139	12	5,5
20"	F35	415	260	356	33	8	105	140	37	28	58,5	2	142	13	5,5
24"	F40	475	300	406	39	8	115	150	42	32	64,5	2	170	13	8,5

Class 900															
DN	ISO	d1	d2	d3	d4	d5	G	G1	K	T	T1	T2	Y	Y1	Y2
1"	F07	90	55	70	9	4	20	32	11	6	12,5	1	34	7,5	3,5
2"	F10	125	70	102	11	4	24	35	12	8	15	1	56	7	3,5
3"	F10	125	70	102	11	4	27	39	12	8	16,5	1	57	7	3,5
4"	F12	150	85	125	13	4	34	47	13	10	20	1	67	8,5	3,5
6"	F14	175	100	140	18	4	50	67	17	14	28,5	2	77	8,5	4,5
8"	F16	210	130	165	22	4	60	78	22	18	34	1	92	10	5,5
10"	F25	300	200	254	18	8	68	86	27	20	38,5	2	101	10,5	5,5
12"	F30	350	230	298	22	8	82	105	32	22	46	2	108	10,5	5,5
14"	F30	350	230	298	22	8	90	120	32	25	50	2	139	12	5,5
16"	F35	415	260	356	33	8	90	120	37	25	50	2	139	12	5,5
18"	F35	415	260	356	33	8	115	150	37	32	64,5	2	145	13	5,5

Class 1500															
DN	ISO	d1	d2	d3	d4	d5	G	G1	K	T	T1	T2	Y	Y1	Y2
1"	F07	90	55	70	9	4	20	32	11	6	12,5	1	34	7,5	3,5
2"	F10	125	70	102	11	4	24	35	12	8	15	1	56	7	3,5
3"	F12	150	85	125	13	4	34	47	13	10	20	1	67	8,5	3,5
4"	F12	150	85	125	13	4	34	47	13	10	20	1	67	8,5	3,5
6"	F16	210	130	165	22	4	50	67	22	14	28,5	2	87	7	5,5
8"	F25	300	200	254	18	8	68	86	27	20	38,5	2	101	10,5	5,5
10"	F25	300	200	254	18	8	68	86	27	20	38,5	2	109	10,5	5,5
12"	F30	350	230	298	22	8	90	120	32	25	50	2	129	12	5,5
14"	F30	350	230	298	22	8	90	120	32	25	50	2	129	12	5,5
16"	F35	415	260	356	33	8	105	140	37	28	58,5	2	140	13	5,5
18"	F35	415	260	356	33	8	115	150	37	32	64,5	2	145	13	5,5

Class 2500															
DN	ISO	d1	d2	d3	d4	d5	G	G1	K	T	T1	T2	Y	Y1	Y2
2"	F10	125	70	102	11	4	27	38	12	8	16,5	1	56	7	3,5
3"	F12	150	85	125	13	4	34	47	13	10	20	1	67	8,5	3,5
4"	F14	175	100	140	18	4	40	53	17	12	23	1	77	6,5	4,5
6"	F16	210	130	165	22	4	50	67	22	14	28,5	2	87	7	5,5
8"	F25	300	200	254	18	8	68	86	27	20	38,5	2	109	10,5	5,5
10"	F30	350	230	298	22	8	82	105	32	22	46	2	129	10,5	5,5
12"	F35	415	260	356	33	8	90	120	37	25	50	2	129	12	5,5
14"	F35	415	260	356	33	8	105	140	37	28	58,5	2	140	13	5,5
16"	F35	415	260	356	33	8	105	140	37	28	58,5	2	140	13	5,5



A) Valve Lubrication

The Valve is grease packed i.e the plug rests on a lubricating film in valve body. The grease has three functions: to protect the internal closing surfaces of the valve from corrosion, to seal the valve, and to contribute to easy handling/lower torque. With an eye to achieving the best possible operation, it is therefore important to relubricate the valve. Lubrication is carried out with a BC-Lubricant Gun (Manually with type BC-1 or pneumatically with type BC-2). The tube of the lubricant gun has a “push-on-head” for direct connection to the valve lubricating nipple. This nipple is the giant Buttonhead Design found on most other valve designs in the industry. The valve should be in fully open position when relubricating. Where the media is compressible (e.g. air or gas) relubrication can also take place in fully closed position. Do not lubricate too fast – the lubricating pressure must distribute itself. If possible make a few minor turns of the plug to distribution of the grease on the sealing surfaces. The interval and quantity of lubricant for relubrication depends on the working condition, for instance the temperature, the operating frequency and the need for tightness. (A high working temperature dries up the lubricant). In case however, where the medium is non-aggressive and the temperature is low, the need for relubrication will be small. It is a matter of experience, but as a guideline and starting point, the values in the table below can be used. The lubrication of the gear is either grease filled gearbox or “principle of dry lubrication”, meaning that a layer of antiseizing paste with a content of molybdenum disulphide is applied to bearings, teeth and worms.

Valve size	Interval for relubrication in working temp.			Quantity of lubricant of each plug Number of strokes by using			
	Up to 60°C	60° to 120°C	120° to 200°C	In cm ³	Gun type BC-1	Gun type BC-2	Numbers of units on the Gun type BC-2
1"	12 months	6 months	3 months	1,3	1	1	
1 ½"	-	-	-	1,5	1	2	
2"	-	-	-	1,8	1	2	
2 ½"	-	-	-	2,0	1	2	
3"	-	-	-	2,4	2	3	
4"	-	-	-	4	3	4	
6"	-	-	-	10	6	10	0,1
8"	-	-	-	30	17	30	0,3
10"	-	-	-	45	25	45	0,45
12"	-	-	-	65	36	65	0,65
14"	-	-	-	95	52	95	0,95
16"	-	-	-	135	75	135	1,35
18"	-	-	-	180	100	180	1,8
20"	-	-	-	235	130	235	2,35
24"	-	-	-	325	180	325	3,25



B) Adjustment of Plug

From the factory the plug is adjusted to the conical bore of the body, and normally it is never readjusted. Readjusting is only done when the valve – even after an effective lubrication – is not tight.

Procedure:

First the bottom screw (12) placed on the underside of the bottom cover, is dismantled. Then the adjustment pressure screw (11) is tightened inwards very slowly while the plug is turned a little forwards and backwards.

The adjustment is a matter of feeling, and there is no exact tighten torque. As a guidance it can be observed, that the operating torque of the valve will increase, when direct contact between plug and body has been obtained. After adjusting, the bottom screw is remounted.

The adjusting can be done without dismantling the valve from the pipeline.

Important:

Normally it is advised, not to turn the adjustment pressure screws outwards. If this is done, there is a risk for the plug to slide out of the seat. Particles from the medium, will then be able to penetrate into the gap, which can result in damages on the closing surfaces.

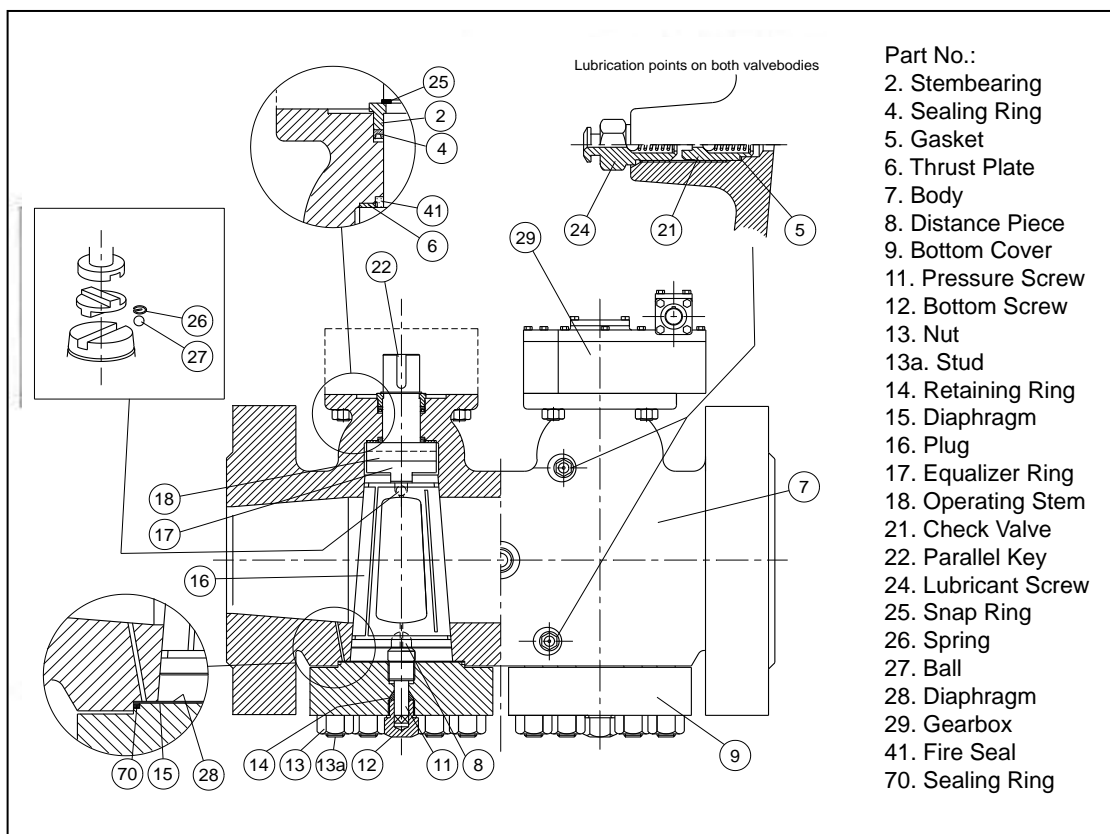



C) Relubrication of Gear Boxes

The gear bearings are lubricated through grease nipples once a year or so. Below is shown the arrangement of the grease nipples on the two gear types. The gear tooth racks on the worms and wheels are, as a rule, never lubricated. However, in case of trouble of control, making handling difficult, a penetrating and almost screaming sound will indicate a lack of lubrication. In such cases, a relubrication of the tooth racks is necessary. For gear type C or D, a removal of the gear covers is necessary to make the gear parts accessible. The lubrication paste is then applied to all tooth racks of both worms and worm wheels in a layer of about 1 mm. (Concentrated powdered molybdenum disulphide cannot be recommended, as layer thickness here is too thin).

Recommended lubricant:

For bearings, worms and gears: BCH G10.

Gear Type C and D are supplied with 2 threaded drain plugs – one in the cover of the gear, the other in the bottom. One of these plugs has a pressure relief valve. Please notice: This plug is always placed in the lower of the 2 thread holes.

The lubricant gun type BC-1 is manual operated, which means the lubricant is pressed into the valve by a high pressure piston pump, when the arm is moved. By turning the handle at the rear end of the gun, the lubricant is pressed forwards against the piston pump. The handle is turned approximately 1/2 turn for each two/three strokes. The lubricant is delivered in 300 ccm cartridges.

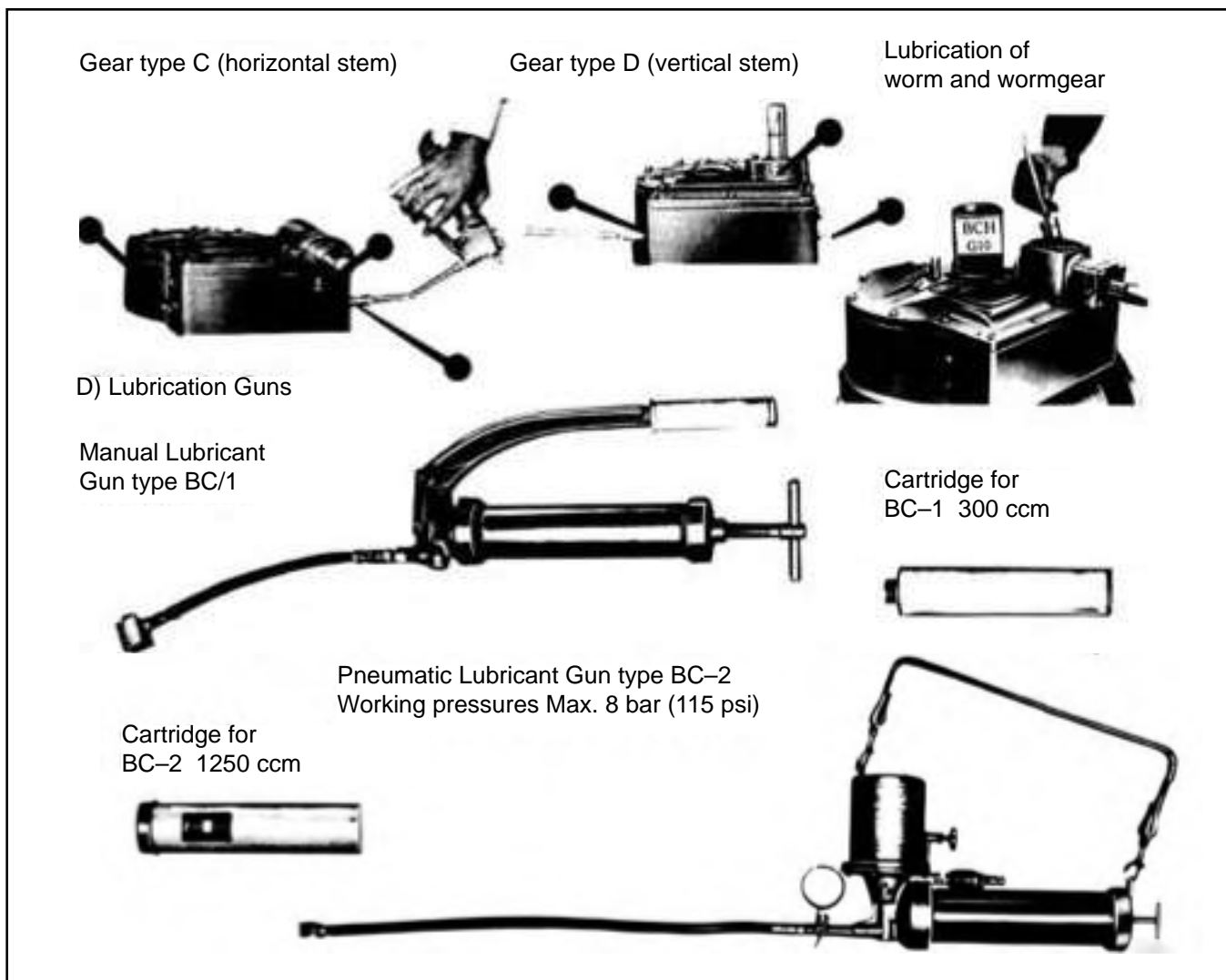



Standard Lubricants – These sealants is to be used whenever possible for optimal performance.

Lubricant no. PR	Colour of compound	Temperature Range		Recommendations
		C	F	
80	Black	- 10 + 180	+ 14 + 356	Cold and hot water up to 180°C, conditional up to 200°C. Cold and hot air. 50% lye up to 50°C conditional up to 100°C, 50% acids up to 50°C, inorganic saline solutions up to 100°C, steam conditional up to 200°C. Suitable for town gas, propane, butane and natural gas. Not suitable for gas condensate.
711	Black	- 10 + 225	+ 14 + 437	Petroleum products. Butane and propane (max 100°C). Gasoline, kerosene, asphalt and bitumen, oils and most hydrocarbon solvents. Also suitable for gases (max 170°C). Cold and hot air. Not suitable for hot water, strong alkalis and aromatic.

Special Lubricants – Normally to be used only where the standard lubricants cannot be used

Lubricant no. PR	Colour of compound	Temperature Range		Recommendations
		C	F	
40	Clear	- 10 + 100	+ 14 + 212	Cold and warm water. General aqueous Solutions. Alcohols.
45	Yellowish-beige clear	- 10 + 130	+ 14 + 266	For drinking water at max 100°C, beer, mineral water, milk, cocoa, cream, ammonia compound, acids and alkali disinfectant, fruit-acid and alcohol.
60	White	- 30 + 250	- 22 + 482	All diluted and concentrated acids and lyes, fluorine, chlorine, bromine, iodine, phosphorus oxychloride, ozone, hydrogen peroxide, all organic solvents (except hydrogen fluoride), all mineral, vegetable and animal oils and fats. Do not affect elastomers and plastics.
103	Green	- 30 + 200	- 22 + 392	General purpose synthetic sealant for liquid and gaseous aliphatic hydrocarbon service suitable for gasoline, kerosene, fuel oils, crude distillates, aviation and jet fuel, natural gas. Not suitable for steam, aromatic solvents, strong acids and alkalies.
280	Black	- 10 + 200	+ 14 + 392	Cold and hot air up to 200°C. Cold and hot water up to 180°C. Cold and hot gases up to 150°C. Not suitable for strong acids, petroleum products and aromatic and chlorinated solvents.
* 330	White	- 30 + 250	- 22 + 482	Hot water and gases. Natural gas, propane, butane, asphalt and bitumen. General chemical aqueous solutions eg. Alkalis and dilute acids. It is useful for hot air. Not suitable for light liquid hydrocarbons, aromatic and chlorinated solvents and strong mineral acids.

* This type of lubricant ought to be avoided, if one of the other types can be used, as this contains silicone oil. The operating torque of the valve will increase considerable. For exceptional working conditions and services not mentioned in the tabel, please ask for further information.

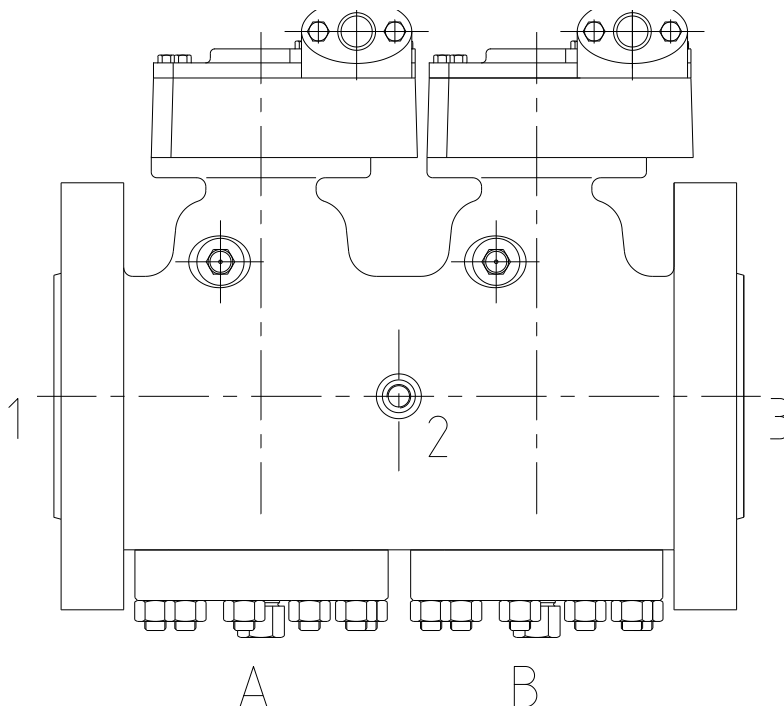

Test No.

1. Test of shell. The shell is tested with both the plugs in open position.
2. Test of plug A in closed position and plug B in open position, pressure at flange no. 1
3. Test of plug B in closed position and plug A in open position, pressure at flange no. 3
4. Test of plug A and B in closed position and pressure at flange no. 1 and 3.
5. Test of plug A and B in closed position and pressure at flange no. 2.

Test no.	Pressure (bar)	Medium	Test duration (min)	Lubrication	Maximum Permissible leakage rate
1	1)	Water	5	3)	No leakage
2	2)	Water	5	3)	4)
3	2)	Water	5	3)	4)
4	2)	Water	5	3)	4)
5	2)	Water	5	3)	4)
2	2)	Water	5	711	No leakage
3	2)	Water	5	711	No leakage
4	2)	Water	5	711	No leakage
5	2)	Water	5	711	No leakage
2	4 to 6	Air	5	711	No leakage
3	4 to 6	Air	5	711	No leakage
4	4 to 6	Air	5	711	No leakage
5	4 to 6	Air	5	711	No leakage

- 1) Hydrostatic Shell test (see page C7)
- 2) Hydrostatic seat test (see page C7)
- 3) Tested without lubricant 711.
- 4) Maximum allowed leakage = Valve DN² x 0,25 ml/min.



After assembling, before delivery, all Christensen Plug Valves pass through a careful pressure test. The test is carried out acc. to the following standards: ASME B. 16.34, BS 1560, BS 6755 API 598 and ASME B16.1. If the customer or his representative wants to participate at the test – or, if there are special requirements to the pressure testing, this must be arranged with the manufacturer and stipulated in the purchase order.

Material	ASME B16.1	($\frac{1}{2}$ " to 12")		Class (14" to 36")			
		125	250	125	250		
Semi Steel ASTM A126 Class B	Maximum Cold PSI Working Pressure BAR	200 13,8	500 34,5			150 11	300 21
	Hydrostatic Shell PSI Test BAR	300 20,7	750 51,8			230 16	450 30
	Seat Test Min. PSI Min. Bar	220 15,2	550 37,9			165 12	

Material		Class						
		150	300	400	600	900	1500	2500
Carbon Steel ASTM A216 Gr. WCB	Maximum Cold PSI Working Pressure BAR	285 19,6	740 51,1	990 68,1	1480 102,1	2220 153,2	3705 255,3	6170 425,5
	Hydrostatic Shell PSI Test BAR	450 30	1125 77	1500 103	2225 154	3350 230	5575 383	9275 639
	Seat Test Min. PSI Min. Bar	315 21,5	815 56,2	1090 74,9	1630 112,3	2442 168,5	4075 280,8	6787 468

Material		Class						
		150	300	400	600	900	1500	2500
Carbon Steel ASTM A352 Gr. LCB	Maximum Cold PSI Working Pressure BAR	265 18,4	695 47,9	925 63,8	1390 95,9	2085 143,8	3470 239,4	5785 399
	Hydrostatic Shell PSI Test BAR	400 28	1050 72	1400 96	2100 144	3150 216	5225 360	8700 599
	Seat Test Min. PSI Min. Bar	292 20,2	765 52,7	1018 70,2	1529 105,5	2294 158,2	3817 263,3	6364 438,9

Material		Class						
		150	300	400	600	900	1500	2500
Stainless Steel ASTM A351 Gr. CF8M	Maximum Cold PSI Working Pressure BAR	275 19,0	720 49,6	960 66,2	1440 99,3	2160 148,9	3600 248,1	6000 413,6
	Hydrostatic Shell PSI Test BAR	425 29	1100 75	1450 100	2175 149	3250 224	5400 373	9000 621
	Seat Test Min. PSI Min. Bar	303 20,9	792 54,6	1056 72,8	1584 109,2	2376 163,7	3960 272,9	6600 454,9

Material		Class						
		150	300	400	600	900	1500	2500
ASTM A216 Gr. WCC ASTM A352 Gr. LCC ASTM A352 Gr. LC2 ASTM A890 Gr. 4A	Maximum Cold PSI Working Pressure BAR	290 20	750 51,7	1000 69	2500 103,4	2250 155,2	3750 258,6	6250 431,0
	Hydrostatic Shell PSI Test BAR	450 30	1125 78	1500 104	2250 156	3375 233	5625 388	9375 647
	Seat Test Min. PSI Min. Bar	319 22	825 56,9	1100 75,9	1650 113,7	2475 170,7	4125 284,5	6875 474



	Class 150				Class 300				Class 400				Class 600	
	Run Torque Nm	Break Torque Nm	Weight Kg	CV. Usgal/m	Run Torque Nm	Break Torque Nm	Weight Kg	CV. Usgal/m	Run Torque Nm	Break Torque Nm	Weight Kg	CV. Usgal/m	Run Torque Nm	Break Torque Nm
DN 1"	18	27	14,6	56	23	35	16	56	30	45	16	56	39	59
DN 2"	48	72	25	175	69	104	25	175	71	107	28	175	118	177
DN 3"	82	123	41	343	121	182	45	343	126	189	52	346	214	321
DN 4"	138	207	76	603	205	308	85	603	208	312	83	603	364	546
DN 6"	326	489	154	1391	478	717	173	1391	520	780	202	1401	906	1359
DN 8"	548	822	235	2420	796	1194	255	2420	887	1331	256	2358	1514	2271
DN 10"	665	998	280	3471	1380	2070	535	3923	1155	1733	543	3370	1954	2931
DN 12"	971	1457	450	5053	1441	2162	495	5053	1776	2664	687	4947	2987	4481
DN 14"	1166	1749	508	6164	1762	2643	578	6164	2080	3120	780	5800	3327	4991
DN 16"	1559	2339	539	8288	2458	3687	645	8288	2867	4301	869	7723	4681	7022
DN 18"	2008	3012	1138	10796	3200	4800	1284	10460	3886	5829	1754	9808	6312	9468
DN 20"	2510	3765	1570	13729	4190	6285	1719	13337	5046	7569	2360	12206	8309	12464
DN 24"									8244	12366	3210	18420	13585	20378

	Class 600		Class 900				Class 1500				Class 2500			
	Weight Kg	CV. Usgal/m	Run Torque Nm	Break Torque Nm	Weight Kg	CV. Usgal/m	Run Torque Nm	Break Torque Nm	Weight Kg	CV. Usgal/m	Run Torque Nm	Break Torque Nm	Weight Kg	CV. Usgal/m
DN 1"	16	56	47	71	23	46	68	102	23	46				
DN 2"	30	175	112	168	56	142	178	267	56	142	173	260	85	90
DN 3"	55	346	203	305	75	303	383	575	112	315	430	645	168	210
DN 4"	87	603	362	543	110	545	546	819	157	490	691	1037	295	332
DN 6"	210	1401	956	1434	260	1242	1226	1839	370	1067	2017	3026	647	796
DN 8"	274	2358	1748	2622	456	2094	2053	3080	646	1769	3997	5996	951	1481
DN 10"	571	3370	2795	4193	715	3199	3393	5090	1170	2762	6109	9164	1850	2239
DN 12"	715	4947	3701	5552	1050	4350	6379	9569	1915	4110	7298	10947	3018	2897
DN 14"	810	5800	5176	7764	1546	5433	6083	9125	2548	4656	9984	14976	*2410	3657
DN 16"	905	7723	7313	10970	1850	7181	8144	12216	3250	6104	9984	14976	*2410	4307
DN 18"	1800	9808	10396	15594	2575	9352	11694	17541	4652	7984				
DN 20"	2410	12206												
DN 24"	3610	18420												

The temperature is 20° Celsius (Ambient)
 Please note, no safety factor included in the valve values
 * The weight is for grayloc Clamp ends.
 The weight is for flange valves with ISO top flange. (The weight is approximate only).
 To convert Nm to foot lb. Multiply by 0.738 (1 Nm = 0.738 ft lb)



BRDR. CHRISTENSEN

CREATING QUALITY VALVES WORLDWIDE

brdrchristensen.eu



Twin plug valve fact sheet

- True double isolation giving two blocks in line all in one valve. (This differs from a DB&B ball valve). The twin plug design offers two blocks in the same direction.
- Lower costs, weight & size compared to the installation of two valves (two balls or two plugs).
- Standard face to face dimensions in most sizes/classes allows for simple retrofit to a single ball, gate or plug valve.
- High intergrity metal to metal seats associated with the tapered lubricated plug valve design.
- Thread less stem incorporating three independent seals.
- Pressure balanced for low torque, reliable operation.
- Patented Christensen Cavity Relief System (CCR System) prevent pressure buildup between the two plugs due to thermal or enviromental forces. This system vents only to pipe area not atmosphere.
- Flow rates comparable to the single plug configuration.
- Field proven in some of the most arduous field sites (erosive and/or dirty applications).
- Low cost compared to a single expanding type Double Block & Bleed Gate valve or two ball valves.
- Verifiable isolation at alle times. Bleed port allows easy accurate assessment of seating integrity at any time.
- Self protecting design actually causes one plug to protect the other.
- Bidirectional design – valve can be installed in any position including upside down.
- Bleed available on either side of body or any end connection.
- Valves also available in Hub ends, weld ends and ASME class 125 and 250.
- Meets industry standards, firesafe, API, ASME, ISO etc.